

Hi-Shear Viscometers

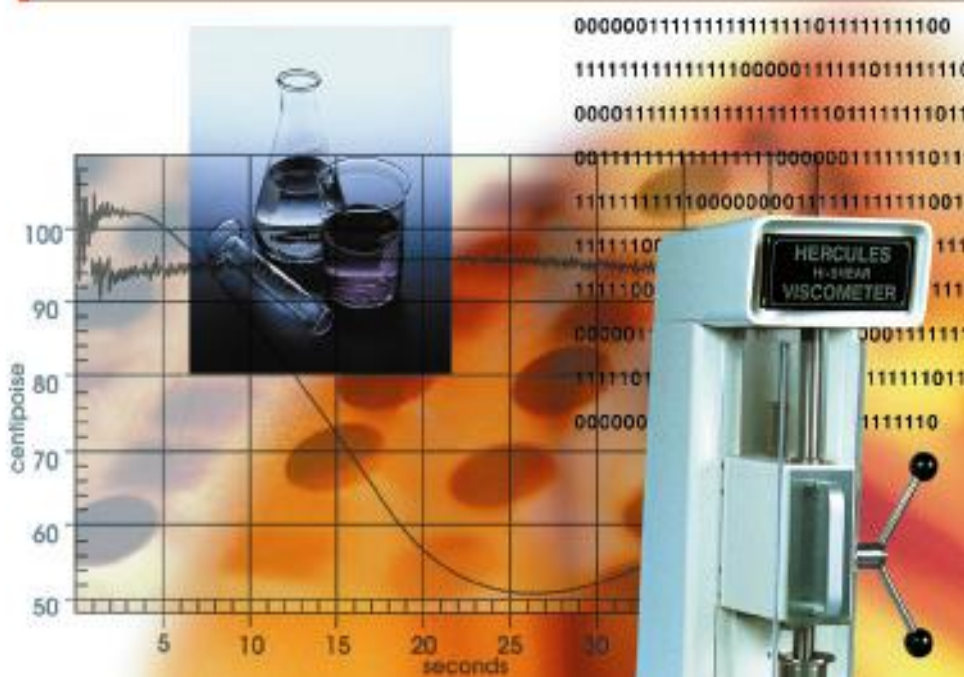

Kaltec Scientific, Inc.

HERCULES®



Generates shear rate ranges up to 185,000 sec⁻¹

TAPPI standard T-648

model

DV-10



HERCULES[®] HI-SHEAR VISCOMETER
Model DV-10

User Guide

HERCULES® HI-SHEAR VISCOMETER, MODEL DV-10

User Guide

© Kaltec Scientific, Inc.
22425 Heslip Drive ♦ Novi, Michigan 48375
Phone 248.349.8100 ♦ Fax 248.349.8909
www.kaltecsci.com



Table of Contents

Guaranty and Certificate of Quality	ii
Description and Features	iii
System Requirements	iv
CHAPTER 1 — VISCOMETER SETUP	
Unpacking the Viscometer	1
General Assembly	2
Computer Hook-up	2
Viscometer Accessories	3
CHAPTER 2 — DV-10 VISCOMETER	
Control Panel	4
LED Indicators	4
Emergency Stop	5
How the Viscometer Works	5
CHAPTER 3 — MAINTENANCE	
Lubricating the Viscometer	6
Preventive Maintenance	6
Cleaning the Viscometer	7
Returning the Viscometer for Service	7
General Troubleshooting	9
CHAPTER 4 — SCHEMATICS	
Replacement Fuse Chart	12

Guaranty and Certificate of Quality

All Hercules® Hi-Shear Viscometers are guaranteed against defects in materials and workmanship for one year providing:

- 1.The defective unit has been operated within published electrical specifications;
- 2.The unit has not been damaged by misuse, improper operation, or accident;
- 3.The unit has not been modified or altered; and
- 4.All costs of transportation of the unit to Kaltec Scientific, Inc., are to be prepaid by the original purchaser.

VISCOMETERS MUST BE RETURNED DIRECTLY TO THE FACTORY, NOT TO THE DISTRIBUTOR OR AGENT FROM WHICH THEY WERE PURCHASED.

Kaltec Scientific, Inc. limits its obligation under this warranty solely to the repair or replacement of any unit returned during the period covered by the warranty. No other obligations or liabilities are implied or expressed. This form also serves as a certificate of quality.

Kaltec Scientific, Inc.

Description and Features

The DV-10 is the ultimate tool for the coating scientist engaged in the research and development of today's complex formulations. This instrument is built around the robust features of the original Hercules[®], and is now teamed up with the power of a computer for high accuracy and repeatability of viscometric measurements.

The Windows software, WinShear, permits a wide variety of test parameters that include maximum RPM, ramp time, and torque range selection. Upon establishing input parameters, the operator has the choice of running the classic test of RPM versus torque (AUTO), TRACE-HOLD-RETURN, or the DILATANT TEST. Tests are displayed in real-time throughout the test cycle, allowing the operator to view results as they occur. Other plots that can be displayed and printed at the completion of the test are:

- ◆ Torque vs. RPM
- ◆ Viscosity vs. Shear Rate
- ◆ Viscosity vs. Time
- ◆ Kinematic Viscosity vs. Shear Rate
- ◆ RPM vs. Torque
- ◆ Shear Stress vs. Shear Rate
- ◆ Viscosity vs. RPM

WinShear also saves time by performing all relevant calculations such as:

- ◆ Viscosity
- ◆ Shear Stress
- ◆ Area Inside the Hysteresis Loop
- ◆ Peak Mechanical Energy Input
- ◆ Shear Rate
- ◆ Reynolds Number
- ◆ Kinematic Viscosity

Test data can be printed out or compiled in a data file for use in other programs.

System Requirements

This section describes the hardware, memory, and disk space requirements for the WinShear Software using a stand-alone computer or a network.

Minimum Computer Specifications:

- ◆ P5 (Pentium 1) Processor, 100 MHz or greater
- ◆ 32 meg of System RAM
- ◆ One (1) high speed serial port featuring a 16550 UART (for real-time graph)
- ◆ VGA monitor 640 x 480 - 256 color capabilities
- ◆ Windows 98 or greater
- ◆ Mouse or pointing device
- ◆ 540 MB hard drive or greater

Viscometer Setup

Please read this manual and any other instructions sent with the instrument before assembling.

ICON KEY

 Valuable information

Your viscometer and its components were inspected and in good working order before leaving the factory. Carefully unpack the viscometer by following the instructions listed below.

 **CAUTION:** Do not pry the crate apart. The viscometer is bolted to the crate. Prying the crate open may damage the instrument and its components.

SUGGESTION: The technician responsible for the instrument's operation should supervise the unpacking and assembly of the viscometer.

Unpacking the Viscometer

You will need the following tools: Phillips Head Screwdriver and 1/2" Wrench or Socket

1. Remove the four (4) screws from the bottom of both side panels of the crate. (Phillips)
2. Lift the outer box straight up to clear the viscometer. **NOTE:** Two people are recommended for this step.
3. Turn the outer box upside down.
4. Remove the three (3) screws from the compartment marked "ADDITIONAL PARTS INSIDE," inside the outer box. (Phillips) This compartment contains a corrugated box which holds the accessories.

5. Elevate the base to remove the four (4) bolts fastened to the body of the viscometer. (1/2" Wrench or Socket)
6. Carefully remove the unit from the base of the crate and place it on a sturdy table or bench.
7. Save the crate and packing materials for future shipping.

General Assembly

Except for a few small components, the unit was shipped pre-assembled. The small components include the following:

- 4 Leveling Mounts
 - 5 Bobs (A, B, C, E, & FF) in a Wooden Bob Box
 - 1 Quick Cup
 - 2 Pinion Levers
 - 1 Electrical Cord
 - 1 Data Communication Cable
1. Screw the four rubber Leveling Mounts into the extended feet of the main casting. Adjust the leveling mounts until the unit stands firmly on the table or bench. (Precision leveling is not required.)
 2. Screw the Pinion Levers in to the Pinion located on the right side of the Spindle Housing.
 3. Connect the Power Cord to the rear of the instrument. Plug the Power Cord into the properly rated and grounded electrical outlet. (Refer to the specification plate affixed to the rear of the unit).

Computer Hook-up

- Connect the round end of the Data Communication Cable to the back of the viscometer.
- Connect the other end of the Data Communication to a serial (COM) port.  (COM 2 is recommended.)

Accessories

The accessories listed below were shipped with the viscometer.

Quick Cup (P/N 10044)

Insert the Quick Cup carefully into the Cup Holder. Align the Cup's key with the Cup Holder's key. Carefully lower the Cup to the bottom. Turn the Cup slightly counterclockwise until the Cup locks into place.  **CAUTION: If the Cup is difficult to remove from the Cup Holder, do not force the Cup out. Forcing the Cup will either damage the Cup or the Cup Holder. To remove, gently tap the Cup with your hand. Lift the Cup straight up. Refer to General Troubleshooting in Chapter 3 for possible causes and how to correct the problem.**

Bobs (P/N 10020 - 10031):

Screw the Bob clockwise no more than finger tight onto the lower, threaded end of the Drive Spindle.  **NOTE: Hold the Drive Spindle only by the flats at the top, using the Spindle Wrench provided.**

Bob Box (P/N 10035):

The Bob Box was specifically designed to hold Bobs A, B, C, E, and FF. The box prevents the Bobs from being damaged while not in use.

Fluid Depth Gauge (P/N 10310):

The line closest to the letter represents the amount of sample necessary for the corresponding Bob.

 **To Use:** Insert the gauge (ball end up) in the Cup. Hold the gauge straight up with the end resting on the bottom of the Cup. Pour the sample into the center of the Cup until it reaches the line on the gauge for the Bob you will be using.

Splash Shield (P/N 12101):

The shield is a safety precaution. It also prevents possible splattering of test material. This shield must be in place while spindle is rotating.

DV-10 Viscometer

Read this chapter to become familiar with the viscometer before operating.

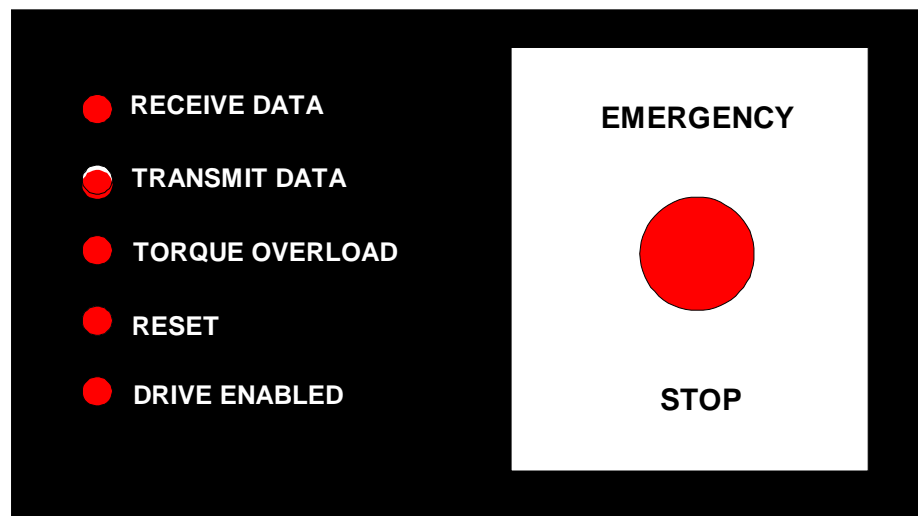

LED Indicators

- **RECEIVE DATA** illuminates when the computer is sending data to the viscometer. The indicator will flash quickly before the test starts.
- **TRANSMIT DATA** illuminates when the viscometer is sending the test results to the computer for analysis. The LED flashes during the test cycle.
- **TORQUE OVERLOAD** illuminates when the torque sensor has reached full scale. There is also an audible tone to indicate the same. The viscometer is designed to

terminate motor rotation and discontinue a test cycle in the event of maximum torque.

- **RESET** will illuminate when there has been an error in either data transmission or reception and when torque overload is illuminating.  Should this occur, reset the viscometer by switching the power “off” for two seconds and then back “on” to resume normal operation.
- **DRIVE ENABLED** illuminates when the power source to the motor is operational. Should this LED turn off, you should check the fuse in the back of the machine. After the unit has been switched off, this LED will remain on for a few minutes while the power supply discharges.

Emergency Stop

Only use the Emergency Stop if there is an uncontrollable test or an adverse circumstance. When the Emergency Stop button is pressed, the rotation of the motor is stopped.

- ⇒ **Activate:** Push down on the button. The drive motor will be disconnected from its power source and data communication between the computer and the viscometer will also stop.
- ⇒ **Deactivate:** Turn the knob clockwise until it releases. The drive motor will be re-connected to its power source and data communication between the computer and viscometer will be back on line.

How the Viscometer Works

The Hercules® Hi-Shear Viscometer is a coaxial cylinder viscometer that uses a Searle sensor system. It produces rheograms (speed versus torque or shear stress versus shear rate) at a wide range of shear rates using a cup and bob configuration.

The sample being tested is confined between two coaxial cylinders and the inner cylinder (bob) is rotated. The viscous drag of the sample induces rotational force to the outside cylinder (cup), which is sensed by a torque sensor. The torque and bob speed are recorded throughout the test and used for all calculations and plot displays.

Maintenance

We recommend that you always do preventive maintenance on the viscometer.

Lubricating the Viscometer

Bi-Monthly:

Clean and lubricate the four areas of the Dovetail Slide that has contact with the Spindle Housing and the top half of the Drive Spindle that slides through the Drive Pulley. Use a heavy lithium grease to do the lubrication. Apply the grease while in both the raised and lowered positions of the Spindle Housing.

Never:

DO NOT lubricate the bearings. All of the bearings are permanently sealed and do not require lubrication. Especially **DO NOT** lubricate the Cup Holder bearings; they are designed for “dry” operation, and any lubrication whatsoever will adversely affect measurement accuracy.

Preventive Maintenance

Your Hercules® DV-10 Hi-Shear Viscometer has been ruggedly designed and has been operated for 50 hours before shipment. Like all fine instruments, however, it is vulnerable to misuse and neglect. Observing the following rules and tips will ensure many years of trouble-free and effective use.

Be especially careful when handling the Cup Holder, and try to protect it from any undue pressures or shocks. **DO NOT** use it as a handle when moving the viscometer. Abuse may result in the Cup Holder shaft becoming bent or damage the torque sensor.

Never force the Cup in to or out of the Cup Holder. If insertion or removal ever becomes more difficult than normal, always check under the cam slot for a recently formed bur. Such a bur should be filed and polished away to prevent interference with the Cup's normal outer dimension.

Keep unit clean. Sample spills and other contaminants can permanently damage some components, especially the Cup Holder bearings.

Never lubricate the Cup Holder bearings.

Clean and lubricate the Dovetail Slide and upper Drive Spindle regularly. **See Lubricating the Viscometer.**

Only qualified technicians should service major problems such as Bob and Cup misalignment, bent shafts, or electronic malfunction.

Cleaning the Viscometer

Unplug the viscometer from the AC power outlet before cleaning. Clean the viscometer after every test. If the sample spills on to the viscometer, wipe it off before it dries. The sample could damage the Cup Holder bearings or other small components.

When washing, use a damp sponge. Water should not run inside the viscometer. This could create an electronic malfunction and cause a shock hazard. Water or cleaning solution should **NEVER** be poured directly on the viscometer. This could cause more damage to the viscometer. **ONLY** clean the outer surface of the viscometer.

Returning the Viscometer for Service

Make certain the malfunction is in your viscometer and not the result of an interface error or a malfunction in your computer or software. If possible, identify the defective area or function.

Call Kaltec's Service Department and receive free unlimited telephone support. If your viscometer is required to return to Kaltec for service, the Service Representative will assign a **Return Authorization Number (RA#)**. Please include this number on all paperwork (especially the shipping labels).

If you need to ship your viscometer back to Kaltec Scientific, pack it in its original crate. If needed, a shipping crate may be obtained from Kaltec. In-transit damage is not covered by the warranty. We suggest that you always insure shipments.

Include the following items when you return your viscometer for service:

- ◆ All Bobs, Cups, & Cup Holders
- ◆ Electrical Cord (1)
- ◆ Leveling Mounts (4)
- ◆ Pinion Levers (2)

Include the following paper work:

1. A brief description of symptoms, software version, and firmware version. (The software version and firmware version can be found on the machine's packing list.)
2. A graph from the Auto test using the A Bob, 1100 RPM, 100,000 Spring, and Kaltec Test Fluid at 25°C.
3. A graph from a test using your sample when the problem occurred.
4. Contact name, address, and a phone number where you may be reached during the day.

When shipping the instrument in, you must pay for all freight. Kaltec will ship the viscometer back to you "Prepaid" and then add it to the invoice. If any shipments are sent to Kaltec "Collect," a service charge of \$10.00 plus the amount of the freight bill will be added your bill.

Ship to: **Kaltec Scientific, Inc.**
22425 Heslip Drive
Novi, Michigan 48375-4138
U.S.A.

On your Bill of Lading list the instrument as follows:

Crated Machinery
NMFC Item #133300, Sub 3
Class 85

For international shipments, the schedule B number for the instrument is:

9026.80.0000

After Kaltec has received and inspected your instrument, a representative from Kaltec will call with the cost of repairs. A purchase order number will be required for repairs to be made.

General Troubleshooting

Symptom: Cup resists attachment and detachment from Cup Holder.

Likely Cause: ♦ Dried sample material in and around Cup Holder.

Solution: ♦ Clean thoroughly with steel wool.

Likely Cause: ♦ Bur has formed on Cup's camlock groove.

Solution: ♦ File bur off.

Likely Cause: ♦ Cup is bent.

Solution: ♦ Replace with a new cup immediately.

Symptom: Spindle Housing tracks poorly.

Likely Cause: ♦ Sample material on Slide.

Solution: ♦ Clean thoroughly with stiff brush.

Likely Cause: ♦ A bur has formed on the Slide.

Solution: ♦ Use fine sandpaper or emery cloth to remove bur and lubricate.

Symptom: Bob does not rotate when running a test.

Likely Cause: ♦ DC fuse (located in back of unit) has blown.

Solution: ♦ Replace with AGC 20 fuse only.

Symptom: Power switch indicator or LEDs do not light up when the power is turned on (and unit is properly plugged in).

Likely Cause: ♦ AC fuse is blown.

Solution: ♦ Contact Kaltec's Service Department before replacing.

Symptom: Drive enabled LED does not illuminate.

Likely Cause: ♦ DC fuse (located in back of unit) has blown.

Solution: ♦ Replace with AGC 20 fuse only.

Symptom: Torque Overload LED is on and sounder is making noise.

Likely Cause: ♦ Emergency Stop button has been pushed.

Solution: ♦ Deactivate Emergency Stop button (see page 5).

Likely Cause: ♦ Full-scale torque has been reached.

Solution: ♦ Switch viscometer off for at least two seconds, then on again.

Schematics

The following schematic is to be used when you need to replace any fuse inside the viscometer.

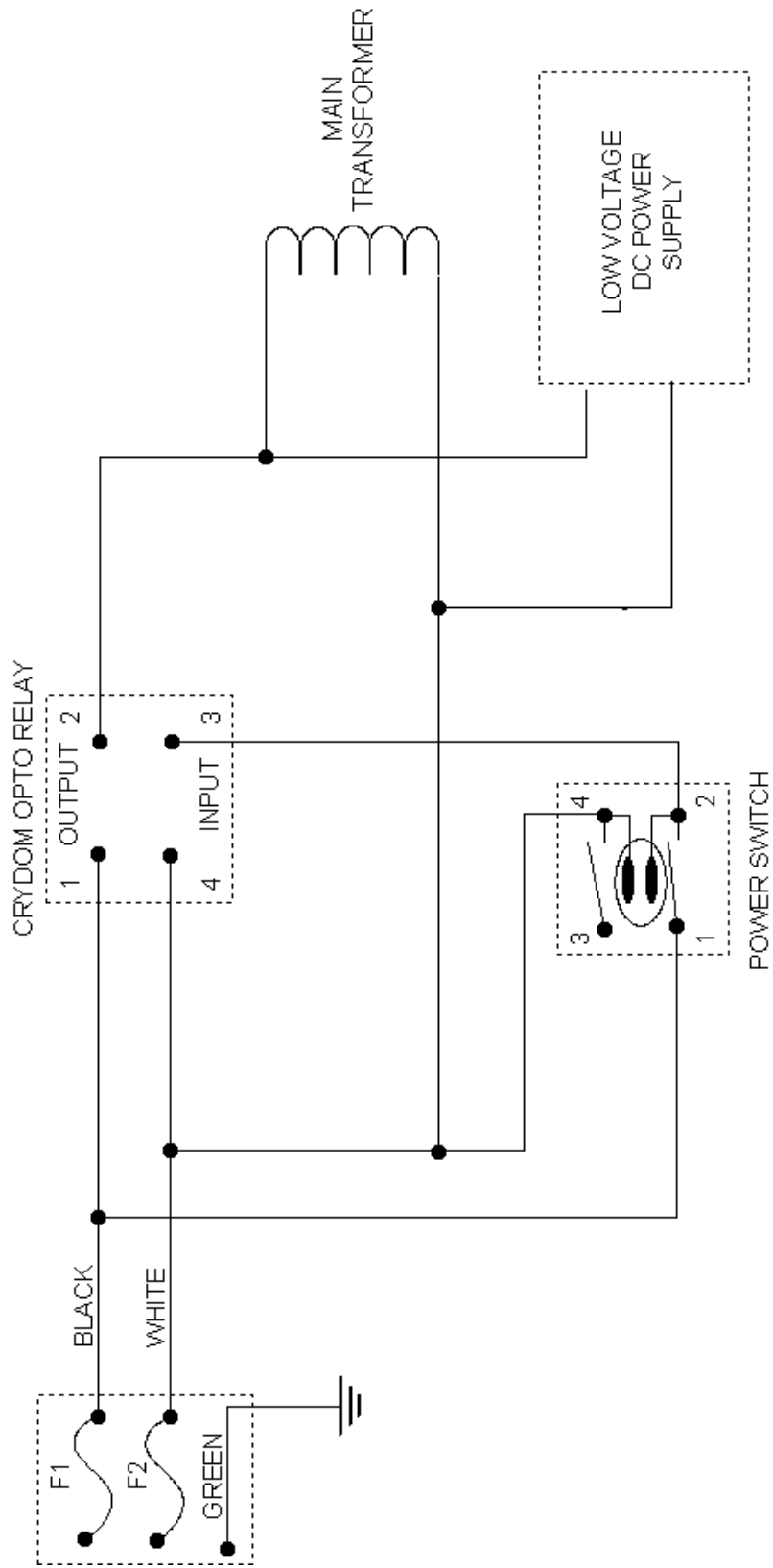

VOLTS	F1	F2	DIMENSIONS	PART #
100 - 120	15 A	15 A	.25" X 1.25"	36167
200 - 240	6.3 A	6.3 A	5mm X 20mm	36173